



Self-aligning ball bearings



Designs	470
Basic design	470
Sealed bearings	470
Bearings with an extended inner ring	470
Bearings on sleeves	471
Self-aligning ball bearing kits	474
Appropriate bearing housings	475
Bearing data – general	476
Dimensions	476
Tolerances	476
Misalignment	476
Internal clearance	476
Cages	478
Axial load carrying capacity	478
Minimum load	479
Equivalent dynamic bearing load	479
Equivalent static bearing load	479
Supplementary designations	479
Mounting bearings with a tapered bore	480
Measuring the clearance reduction	480
Measuring the lock nut tightening angle	481
Measuring the axial drive-up	481
Additional mounting information	482
Product tables	484
Self-aligning ball bearings	484
Sealed self-aligning ball bearings	492
Self-aligning ball bearings with extended inner ring	494
Self-aligning ball bearings on adapter sleeve	496

Designs

The self-aligning ball bearing was invented by SKF. It has two rows of balls and a common sphered raceway in the outer ring. The bearing is consequently self-aligning and insensitive to angular misalignments of the shaft relative to the housing. It is particularly suitable for applications where considerable shaft deflections or misalignment are to be expected. Additionally, the self-aligning ball bearing has the lowest friction of all rolling bearings, which enables it to run cooler even at high speeds.

SKF produces self-aligning ball bearings to several designs. These are

- open bearings of the basic design (→ **fig. 1**)
- sealed bearings (→ **fig. 2**)
- open bearings with an extended inner ring (→ **fig. 3**).

Basic design

The basic design self-aligning ball bearing is available with a cylindrical bore or, in certain size ranges, with a tapered bore (taper 1:12).

Large self-aligning ball bearings in the 130 and 139 series originally developed for specific applications in paper mills, can be used in any application where low friction is preferred over high load carrying capacity. These bearings are provided with an annular groove and lubrication holes in the outer ring and lubrication holes in the inner ring (→ **fig. 4**).

The balls of some bearings in the 12 and 13 series protrude from the sides of the bearing. The values of the protrusion are provided in **table 1** and should be considered when designing the associated components of the bearing arrangement.

Sealed bearings

SKF self-aligning ball bearings are also available in a sealed version with contact seals on both sides – designation suffix 2RS1 (→ **fig.5**). These sheet steel reinforced seals are made of oil and wear-resistant acrylonitrile-butadiene rubber (NBR). The permissible operating temperature range for these seals is -40 to $+100$ °C and up to $+120$ °C for brief periods. The seal lip contacts a smooth chamfer on the inner ring with light pressure.

Fig. 1

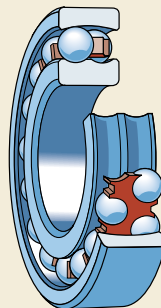

Fig. 2

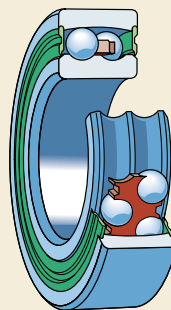

Fig. 3

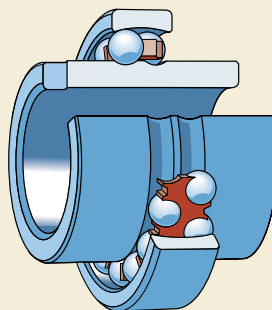

Fig. 4

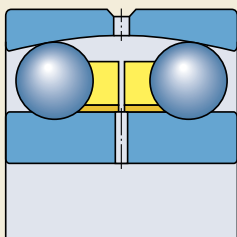
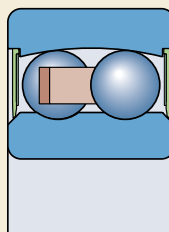

Fig. 5



Sealed bearings are lubricated as standard with a grease with lithium thickener that has good rust inhibiting properties and other characteristics according to **table 2**.

SKF sealed self-aligning ball bearings are available with a cylindrical bore. Some sizes are also available with a tapered bore (taper 1:12).

Note

Sealed bearings are lubricated for life and require no maintenance. They should not be heated above 80 °C before mounting and should not be washed.

Table 1

Protrusion of balls from bearing side faces

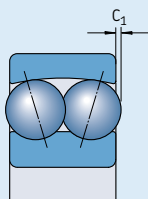

Bearing	Protrusion C_1 mm
1224 (K)	1,3
1226	1,4
1318 (K)	1
1319 (K)	1,5
1320 (K)	2,5
1322 (K)	2,6

Table 2

SKF standard grease filling for sealed self-aligning ball bearings

Technical specification	SKF greases MT47	MT33
Bearing outside diameter, mm	≤ 62	>62
Thickener	Lithium soap	Lithium soap
Base oil type	Mineral oil	Mineral oil
NLGI consistency class	2	3
Temperature range, °C¹⁾	-30 to +110	-30 to +120
Base oil viscosity, mm²/s		
at 40 °C	70	98
at 100 °C	7,3	9,4

¹⁾ For safe operating temperature, → section "Temperature range – the SKF traffic light concept", starting on **page 232**

Bearings with an extended inner ring

Self-aligning ball bearings with an extended inner ring are designed for less demanding applications using commercial grade shafting. The special bore tolerance enables easy mounting and dismounting.

Self-aligning ball bearings with an extended inner ring are axially located on the shaft by means of a pin or shouldered screw (→ **fig. 6**), which engages in a slot at one side of the inner ring and also prevents the inner ring from turning on the shaft.

When two self-aligning ball bearings with an extended inner ring are used to support a shaft, they should be positioned so that the inner ring slots either face each other, or are at the out-board positions of the bearings (→ **fig. 7**). If this is not the case, the shaft is axially located in one direction only.

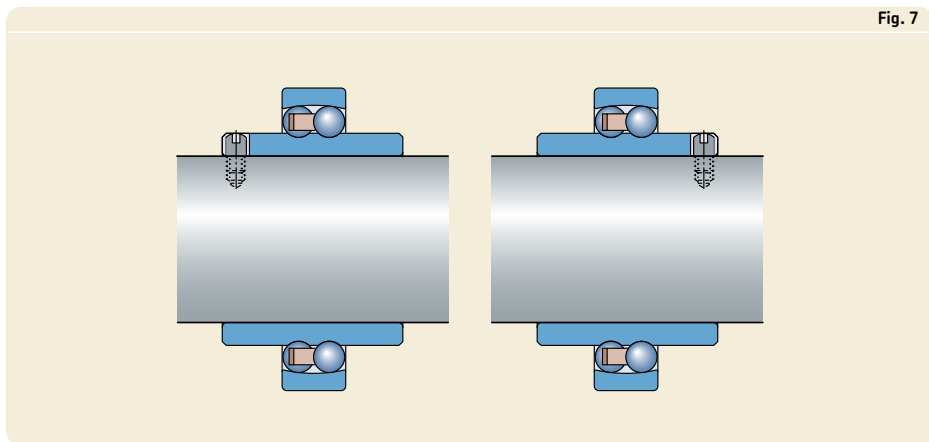
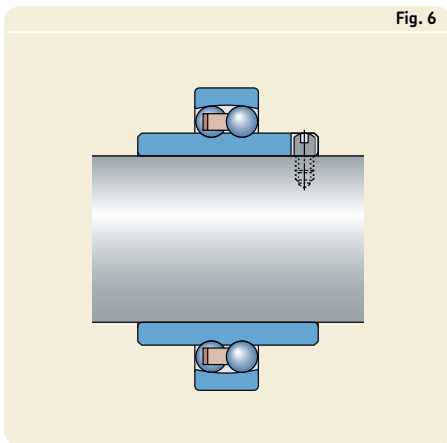

Bearings on sleeves

Adapter and withdrawal sleeves are used to secure bearings with a tapered bore onto cylindrical shaft seats. They facilitate bearing mounting and dismounting and often simplify bearing arrangement design.

Adapter sleeves (→ **figs. 8 and 9**) are more popular than withdrawal sleeves (→ **fig. 10**) as they do not require axial locating devices on the shaft. That is why only adapter sleeves are shown together with suitable bearings in the product table, starting on **page 496**.

SKF adapter sleeves are slotted and are supplied complete with lock nut and locking device. The adapter sleeves for use with sealed self-aligning ball bearings are equipped with a special locking washer that has a protrusion on the side facing the bearing, in order to prevent the seal from being damaged (→ **fig. 11**). These sleeves are identified by the suffix C.

Fig. 8



Fig. 9

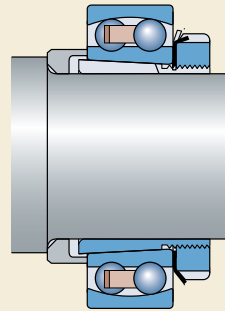

Fig. 11

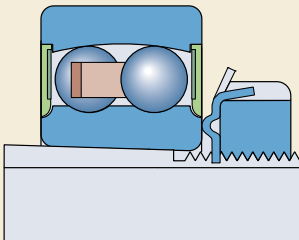
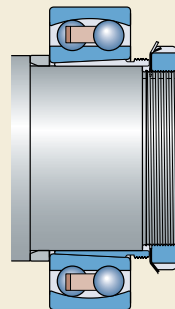

Fig. 10



Self-aligning ball bearing kits

To facilitate procurement and to provide the correct bearing/sleeve combination, SKF offers the most popular self-aligning ball bearings together with the suitable adapter sleeve as a kit (→ **fig. 12**).

Mounting can easily be performed with the help of the SKF lock nut spanner set TMHN 7 (→ **page 1070**).

The range of these kits is shown in **table 3**.

Table 3

SKF self-aligning ball bearing/adapter sleeve kits

Bearing kit Designation	Parts		Shaft diameter mm
	Designation Bearing	Sleeve	
KAM 1206	1206 EKTN9/C3	H 206	25
KAM 1207	1207 EKTN9/C3	H 207	30
KAM 1208	1208 EKTN9/C3	H 208	35
KAM 1209	1209 EKTN9/C3	H 209	40
KAM 1210	1210 EKTN9/C3	H 210	45
KAM 1211	1211 EKTN9/C3	H 211	50

The technical data are provided in the product table on **pages 496 to 499**

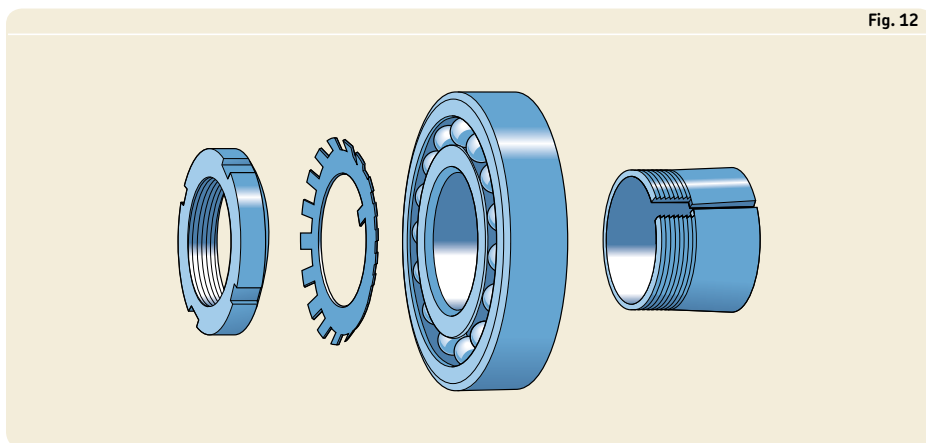

Fig. 12

Appropriate bearing housings

Self-aligning ball bearings with a cylindrical bore or with a tapered bore on adapter sleeve can be mounted in a variety of housings, such as

- SNL plummer (pillow) block housings in the 2, 3, 5 and 6 series (→ **fig. 13**)
- TVN housings
- 7225(00) flanged housings
- SAF plummer (pillow) block housings for inch-size shafts.

Bearings with an extended inner ring can be mounted in specially designed housings, such as

- TN housings
- I-1200(00) flanged housings.

A brief description of these housings is provided in the section “Bearing housings”, starting on **page 1031**. Detailed information on these housings can be found in the “SKF Interactive Engineering Catalogue” on CD-ROM or online at www.skf.com.

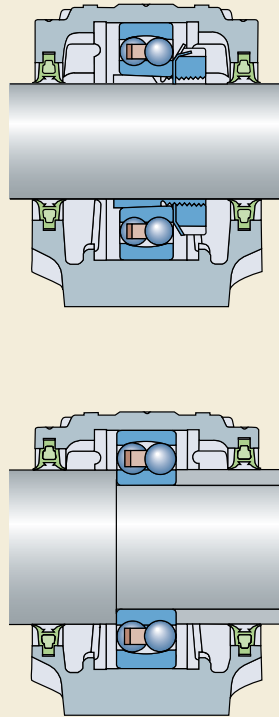

Bearing data – general

Dimensions

The boundary dimensions of SKF self-aligning ball bearings, with the exception of those with an extended inner ring, are in accordance with ISO 15:1998. The dimensions of the bearings with an extended inner ring follow DIN 630, part 2, withdrawn in 1993.

Tolerances

SKF self-aligning ball bearings are manufactured as standard to Normal tolerances, except the bore of the bearings with extended inner ring, which is produced to tolerance JS7.

The values of the Normal tolerances are in accordance with ISO 492:2002 and can be found in **table 3** on **page 125**.

Misalignment

The design of self-aligning ball bearings is such that angular misalignment between the outer and the inner rings can be accommodated without any negative effect on bearing performance.

Guideline values for the permissible angular misalignment between outer and inner rings under normal operating conditions are provided in **table 4**. Whether these values can be fully exploited depend on the bearing arrangement design and the type of seal used.

Internal clearance

SKF self-aligning ball bearings are produced as standard with Normal radial internal clearance and most are also available with the greater C3 clearance. Many bearings can also be supplied with the smaller C2 clearance or the much greater C4 clearance.

Bearings in the 130 and 139 series have C3 radial internal clearance as standard.

Bearings with an extended inner ring have a radial internal clearance which lies in the C2 + Normal range.

Clearance values are provided in **table 5** and are in accordance with ISO 5753:1991. They are valid for unmounted bearings under zero measuring loads.

Table 4

Permissible angular misalignment

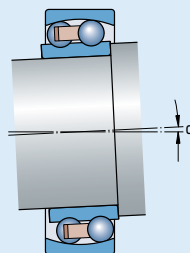

Bearings/ series	Misalignment α degrees
–	degrees
108, 126, 127, 129, 135	3
12 (E)	2,5
13 (E)	3
22 (E)	2,5
22 E-2RS1	1,5
23 (E)	3
23 E-2RS1	1,5
112 (E)	2,5
130, 139	3

Table 5

Radial internal clearance of self-aligning ball bearings

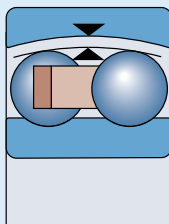

Bore diameter		Radial internal clearance									
d	incl.	C2				Normal		C3		C4	
over		min	max	min	max	min	max	min	max	min	max
mm		μm									
Bearings with a cylindrical bore											
2,5	6	1	8	5	15	10	20	15	25		
6	10	2	9	6	17	12	25	19	33		
10	14	2	10	6	19	13	26	21	35		
14	18	3	12	8	21	15	28	23	37		
18	24	4	14	10	23	17	30	25	39		
24	30	5	16	11	24	19	35	29	46		
30	40	6	18	13	29	23	40	34	53		
40	50	6	19	14	31	25	44	37	57		
50	65	7	21	16	36	30	50	45	69		
65	80	8	24	18	40	35	60	54	83		
80	100	9	27	22	48	42	70	64	96		
100	120	10	31	25	56	50	83	75	114		
120	140	10	38	30	68	60	100	90	135		
140	150	–	–	–	–	70	120	–	–		
150	180	–	–	–	–	80	130	–	–		
180	200	–	–	–	–	90	150	–	–		
200	220	–	–	–	–	100	165	–	–		
220	240	–	–	–	–	110	180	–	–		
Bearings with a tapered bore											
18	24	7	17	13	26	20	33	28	42		
24	30	9	20	15	28	23	39	33	50		
30	40	12	24	19	35	29	46	40	59		
40	50	14	27	22	39	33	52	45	65		
50	65	18	32	27	47	41	61	56	80		
65	80	23	39	35	57	50	75	69	98		
80	100	29	47	42	68	62	90	84	116		
100	120	35	56	50	81	75	108	100	139		

Please refer to **page 137** for the definition of radial internal clearance

Self-aligning ball bearings

Cages

Depending on the bearing series and size, SKF self-aligning ball bearings are fitted as standard with one of the following cages (→ fig. 14)

- a one-piece pressed steel cage, ball centred, no designation suffix (**a**)
- a two-piece pressed steel cage, ball centred, no designation suffix (**b**)
- a one-piece (**c**) or two-piece injection moulded snap-type cage of glass fibre reinforced polyamide 6,6, ball centred, designation suffix TN9
- a one-piece (**c**) or two-piece injection moulded snap-type cage of polyamide 6,6, ball centred, designation suffix TN
- a one-piece or two-piece (**d**) machined brass cage, ball centred, designation suffix M or no suffix (large size).

Contact SKF for availability of bearings with non-standard cages.

Note

Self-aligning ball bearings with polyamide 6,6 cages can be operated at temperatures up to +120 °C. The lubricants generally used for rolling bearings do not have a detrimental effect on cage properties, with the exception of a few synthetic oils and greases with a synthetic oil base, and lubricants containing a high proportion of EP additives when used at high temperatures.

For bearing arrangements, which are to be operated at continuously high temperatures or under arduous conditions, it is recommended to

use bearings with a pressed steel or machined brass cage.

For detailed information about the temperature resistance and the applicability of cages, please refer to the section “Cage materials”, starting on **page 140**.

Axial load carrying capacity

The ability of a self-aligning ball bearing mounted on an adapter sleeve on smooth shafts without an integral shoulder to carry axial loads, depends on the friction between the sleeve and shaft. The permissible axial load can be approximately determined from

$$F_{ap} = 0,003 B d$$

where

F_{ap} = maximum permissible axial load, kN

B = bearing width, mm

d = bearing bore diameter, mm

Fig. 14

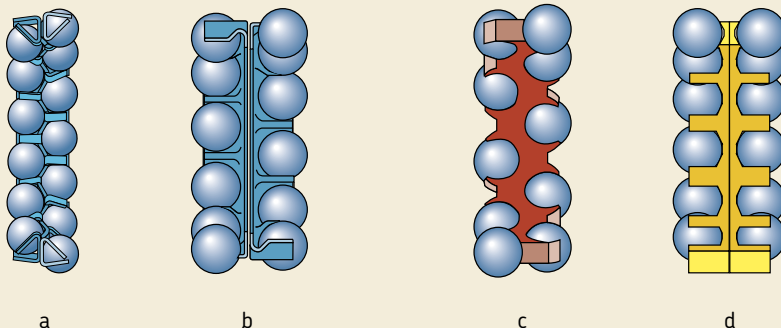

Minimum load

In order to provide satisfactory operation, self-aligning ball bearings, like all ball and roller bearings, must always be subjected to a given minimum load, particularly if they are to operate at high speeds or are subjected to high accelerations or rapid changes in the direction of load. Under such conditions, the inertia forces of the balls and cage, and the friction in the lubricant, can have a detrimental influence on the rolling conditions in the bearing arrangement and may cause damaging sliding movements to occur between the balls and raceways.

The requisite minimum load to be applied to self-aligning ball bearings can be estimated using

$$P_m = 0,01 C_0$$

where

P_m = equivalent minimum load, kN

C_0 = basic static load rating, kN
(→ product tables)

When starting up at low temperatures or when the lubricant is highly viscous, even greater minimum loads may be required. The weight of the components supported by the bearing, together with external forces, generally exceeds the requisite minimum load. If this is not the case, the self-aligning ball bearing must be subjected to an additional radial load, for example, by increasing belt tension or by similar means.

Equivalent dynamic bearing load

$$P = F_r + Y_1 F_a \quad \text{when } F_a/F_r \leq e$$

$$P = 0,65 F_r + Y_2 F_a \quad \text{when } F_a/F_r > e$$

Values of Y_1 , Y_2 and e can be found in the product tables.

Equivalent static bearing load

$$P_0 = F_r + Y_0 F_a$$

Values of Y_0 can be found in the product tables.

Supplementary designations

The designation suffixes used to identify certain features of SKF self-aligning ball bearings are explained in the following.

- C3** Radial internal clearance greater than Normal
- E** Optimized internal design
- K** Tapered bore, taper 1:12
- M** Machined brass cage, ball centred
- TN** Injection moulded snap-type cage of polyamide 6,6, ball centred
- TN9** Injection moulded snap-type cage of glass fibre reinforced polyamide 6,6, ball centred
- 2RS1** Sheet steel reinforced contact seal of acrylonitrile-butadiene rubber (NBR) on both sides of the bearing

Mounting bearings with a tapered bore

Self-aligning ball bearings with a tapered bore are always mounted with an interference fit on a tapered shaft seating or an adapter or withdrawal sleeve. As a measure of the degree of interference of the fit, either the reduction in radial internal clearance of the bearing or the axial displacement of the inner ring on its tapered seating is used.

Suitable methods for mounting self-aligning ball bearings with tapered bore are:

- Measuring the clearance reduction.
- Measuring the lock nut tightening angle.
- Measuring the axial drive-up.

Measuring the clearance reduction

When mounting basic design self-aligning ball bearings with the relatively small Normal radial internal clearance, it is generally sufficient to check clearance during the drive-up by turning and swivelling out the outer ring. When the bearing is properly mounted the outer ring can be easily turned but there should be a slight resistance when the outer ring is swivelled out. The bearing will then have the requisite interference fit. In some cases the residual internal clearance may be too small for the application, and a bearing with C3 radial internal clearance should be used instead.

Table 6

Mounting self-aligning ball bearings with a tapered bore

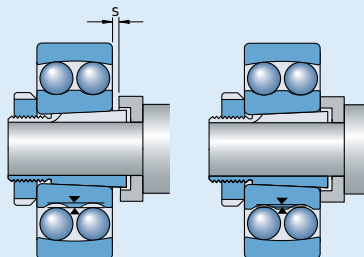

Bore diameter d	Tightening angle α	Axial drive-up s
mm	degrees	mm
20	80	0,22
25	55	0,22
30	55	0,22
35	70	0,30
40	70	0,30
45	80	0,35
50	80	0,35
55	75	0,40
60	75	0,40
65	80	0,40
70	80	0,40
75	85	0,45
80	85	0,45
85	110	0,60
90	110	0,60
95	110	0,60
100	110	0,60
110	125	0,70
120	125	0,70

Measuring the lock nut tightening angle

The procedure for using the nut tightening angle α (→ **fig. 15**) represents an easy method for mounting self-aligning ball bearings with a tapered bore correctly. Recommended values for the nut tightening angle α are provided in **table 6**.

Before starting the final tightening procedure, the bearing should be pushed up on the tapered seating until the bore of the bearing or sleeve is in contact with the seating on the shaft around its whole circumference, i.e. the bearing inner ring cannot be rotated relatively to the shaft. By then turning the nut through the given angle α , the bearing will be pressed up the tapered seating. The residual clearance of the bearing should be checked by turning and swivelling out the outer ring.

Then unscrew the nut, place the locking washer in position and tighten the nut firmly again. Lock the nut by bending one of the locking washer tabs into one of the nut slots.

Measuring the axial drive-up

Mounting bearings with a tapered bore can be done by measuring the axial drive-up of the inner ring on its seating. Recommended values for the required axial drive-up "s" for general applications are provided in **table 6**.

The most suitable method in this case is the SKF Drive-up Method. This mounting method provides a very reliable and easy way to determine the starting position for a bearing from which the axial displacement is to be measured. For that, the following mounting tools (→ **fig. 16**) must be used

- an SKF hydraulic nut of the HMV .. E design (**a**)
- an appropriate hydraulic pump (**b**)
- a pressure gauge (**c**), appropriate to the mounting conditions
- a dial gauge (**d**).

Fig. 15

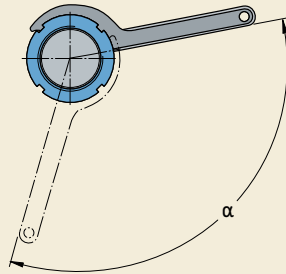
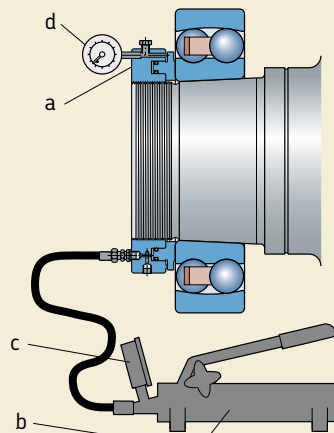

Fig. 16



Self-aligning ball bearings

Applying the SKF Drive-up Method, the bearing is pushed up its seating to a defined starting position (→ **fig. 17**) using a given oil pressure (corresponding to a given drive-up force) in the hydraulic nut. In this way, part of the desired reduction in radial internal clearance is achieved. The oil pressure is monitored by the pressure gauge. The bearing is then driven up from the defined starting position through a given distance to its final position. The axial displacement " s_s " is accurately determined using the dial gauge mounted on the hydraulic nut.

SKF has determined values of the requisite oil pressure and the axial displacement for individual bearings. These values apply to bearing arrangements (→ **fig. 18**) with

- one sliding interface (**a** and **b**) or
- two sliding interfaces (**c**).

Additional mounting information

Additional information on mounting self-aligning ball bearings in general or with the aid of the SKF Drive-up Method can be found

- in the handbook "SKF Drive-up Method" on CD-ROM
- online at www.skf.com/mount.

Fig. 17

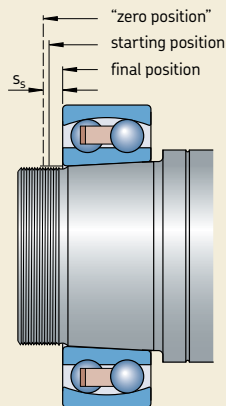
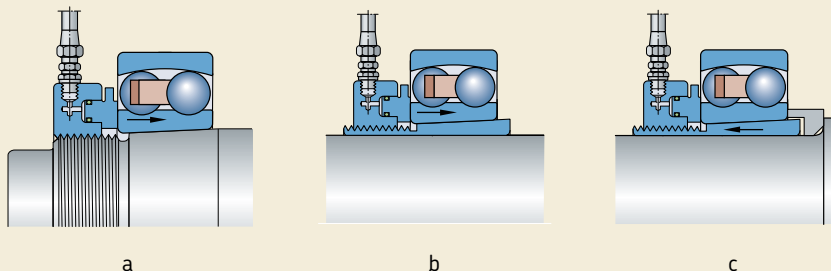
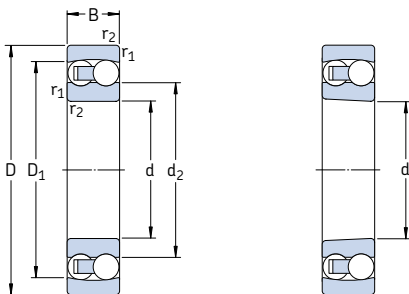

Fig. 18



Self-aligning ball bearings

d 5 – 25 mm



Cylindrical bore

Tapered bore

Principal dimensions			Basic load ratings		Fatigue load limit P_u	Speed ratings		Mass	Designations	
d	D	B	C	C_0		Reference speed	Limiting speed		Bearing with cylindrical bore	tapered bore
mm			kN		kN	r/min		kg	–	
5	19	6	2,51	0,48	0,025	63 000	45 000	0,009	135 TN9	–
6	19	6	2,51	0,48	0,025	70 000	45 000	0,009	126 TN9	–
7	22	7	2,65	0,56	0,029	63 000	40 000	0,014	127 TN9	–
8	22	7	2,65	0,56	0,029	60 000	40 000	0,014	108 TN9	–
9	26	8	3,90	0,82	0,043	60 000	38 000	0,022	129 TN9	–
10	30	9	5,53	1,18	0,061	56 000	36 000	0,034	1200 ETN9	–
	30	14	8,06	1,73	0,090	50 000	34 000	0,047	2200 ETN9	–
12	32	10	6,24	1,43	0,072	50 000	32 000	0,040	1201 ETN9	–
	32	14	8,52	1,90	0,098	45 000	30 000	0,053	2201 ETN9	–
	37	12	9,36	2,16	0,12	40 000	28 000	0,067	1301 ETN9	–
	37	17	11,7	2,70	0,14	38 000	28 000	0,095	2301	–
15	35	11	7,41	1,76	0,09	45 000	28 000	0,049	1202 ETN9	–
	35	14	8,71	2,04	0,11	38 000	26 000	0,060	2202 ETN9	–
	42	13	10,8	2,60	0,14	34 000	24 000	0,094	1302 ETN9	–
	42	17	11,9	2,90	0,15	32 000	24 000	0,12	2302	–
17	40	12	8,84	2,20	0,12	38 000	24 000	0,073	1203 ETN9	–
	40	16	10,6	2,55	0,14	34 000	24 000	0,088	2203 ETN9	–
	47	14	12,7	3,40	0,18	28 000	20 000	0,12	1303 ETN9	–
	47	19	14,6	3,55	0,19	30 000	22 000	0,16	2303	–
20	47	14	12,7	3,4	0,18	32 000	20 000	0,12	1204 ETN9	1204 EKTN9
	47	18	16,8	4,15	0,22	28 000	20 000	0,14	2204 ETN9	–
	52	15	14,3	4	0,21	26 000	18 000	0,16	1304 ETN9	–
	52	21	18,2	4,75	0,24	26 000	19 000	0,22	2304 TN	–
25	52	15	14,3	4	0,21	28 000	18 000	0,14	1205 ETN9	1205 EKTN9
	52	18	16,8	4,4	0,23	26 000	18 000	0,16	2205 ETN9	2205 EKTN9
	62	17	19	5,4	0,28	22 000	15 000	0,26	1305 ETN9	1305 EKTN9
	62	24	27	7,1	0,37	22 000	16 000	0,34	2305 ETN9	–

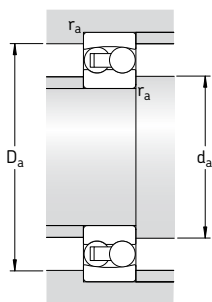

Dimensions				Abutment and fillet dimensions			Calculation factors			
d	d ₂	D ₁	r _{1,2} min	d _a min	D _a max	r _a max	e	Y ₁	Y ₂	Y ₀
mm				mm			-			
5	10,3	15,4	0,3	7,4	16,6	0,3	0,33	1,9	3	2
6	10,3	15,4	0,3	8,4	16,6	0,3	0,33	1,9	3	2
7	12,6	17,6	0,3	9,4	19,6	0,3	0,33	1,9	3	2
8	12,6	17,6	0,3	10,4	19,6	0,3	0,33	1,9	3	2
9	14,8	21,1	0,3	11,4	23,6	0,3	0,33	1,9	3	2
10	16,7	24,4	0,6	14,2	25,8	0,6	0,33	1,9	3	2
	15,3	24,3	0,6	14,2	25,8	0,6	0,54	1,15	1,8	1,3
12	18,2	26,4	0,6	16,2	27,8	0,6	0,33	1,9	3	2
	17,5	26,5	0,6	16,2	27,8	0,6	0,50	1,25	2	1,3
	20	30,8	1	17,6	31,4	1	0,35	1,8	2,8	1,8
	18,6	31	1	17,6	31,4	1	0,60	1,05	1,6	1,1
15	21,2	29,6	0,6	19,2	30,8	0,6	0,33	1,9	3	2
	20,9	30,2	0,6	19,2	30,8	0,6	0,43	1,5	2,3	1,6
	23,9	35,3	1	20,6	36,4	1	0,31	2	3,1	2,2
	23,2	35,2	1	20,6	36,4	1	0,52	1,2	1,9	1,3
17	24	33,6	0,6	21,2	35,8	0,6	0,31	2	3,1	2,2
	23,8	34,1	0,6	21,2	35,8	0,6	0,43	1,5	2,3	1,6
	28,9	41	1	22,6	41,4	1	0,30	2,1	3,3	2,2
	25,8	39,4	1	22,6	41,4	1	0,52	1,2	1,9	1,3
20	28,9	41	1	25,6	41,4	1	0,30	2,1	3,3	2,2
	27,4	41	1	25,6	41,4	1	0,40	1,6	2,4	1,6
	33,3	45,6	1,1	27	45	1	0,28	2,2	3,5	2,5
	28,8	43,7	1,1	27	45	1	0,52	1,2	1,9	1,3
25	33,3	45,6	1	30,6	46,4	1	0,28	2,2	3,5	2,5
	32,3	46,1	1	30,6	46,4	1	0,35	1,8	2,8	1,8
	37,8	52,5	1,1	32	55	1	0,28	2,2	3,5	2,5
	35,5	53,5	1,1	32	55	1	0,44	1,4	2,2	1,4

Self-aligning ball bearings
d 30 – 65 mm

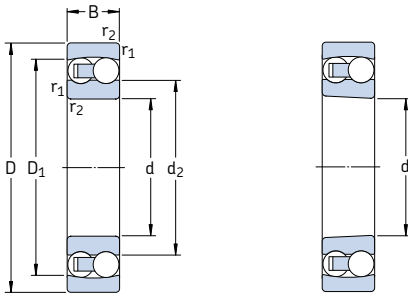

Cylindrical bore

Tapered bore

Principal dimensions			Basic load ratings		Fatigue load limit P_u	Speed ratings		Mass	Designations	
d	D	B	C	C_0		Reference speed	Limiting speed		Bearing with cylindrical bore	tapered bore
mm			kN		kN	r/min		kg	–	
30	62	16	15,6	4,65	0,24	24 000	15 000	0,22	1206 ETN9	1206 EKTN9
	62	20	23,8	6,7	0,35	22 000	15 000	0,26	2206 ETN9	2206 EKTN9
	72	19	22,5	6,8	0,36	19 000	13 000	0,39	1306 ETN9	1306 EKTN9
	72	27	31,2	8,8	0,45	18 000	13 000	0,50	2306 ETN9	2306 K
35	72	17	19	6	0,31	20 000	13 000	0,32	1207 ETN9	1207 EKTN9
	72	23	30,7	8,8	0,46	18 000	12 000	0,40	2207 ETN9	2207 EKTN9
	80	21	26,5	8,5	0,43	16 000	11 000	0,51	1307 ETN9	1307 EKTN9
	80	31	39,7	11,2	0,59	16 000	12 000	0,68	2307 ETN9	2307 EKTN9
40	80	18	19,9	6,95	0,36	18 000	11 000	0,42	1208 ETN9	1208 EKTN9
	80	23	31,9	10	0,51	16 000	11 000	0,51	2208 ETN9	2208 EKTN9
	90	23	33,8	11,2	0,57	14 000	9 500	0,68	1308 ETN9	1308 EKTN9
	90	33	54	16	0,82	14 000	10 000	0,93	2308 ETN9	2308 EKTN9
45	85	19	22,9	7,8	0,40	17 000	11 000	0,47	1209 ETN9	1209 EKTN9
	85	23	32,5	10,6	0,54	15 000	10 000	0,55	2209 ETN9	2209 EKTN9
	100	25	39	13,4	0,70	12 000	8 500	0,96	1309 ETN9	1309 EKTN9
	100	36	63,7	19,3	1	13 000	9 000	1,25	2309 ETN9	2309 EKTN9
50	90	20	26,5	9,15	0,48	16 000	10 000	0,53	1210 ETN9	1210 EKTN9
	90	23	33,8	11,2	0,57	14 000	9 500	0,60	2210 ETN9	2210 EKTN9
	110	27	43,6	14	0,72	12 000	8 000	1,20	1310 ETN9	1310 EKTN9
	110	40	63,7	20	1,04	14 000	9 500	1,65	2310 ETN9	2310 K
55	100	21	27,6	10,6	0,54	14 000	9 000	0,71	1211 ETN9	1211 EKTN9
	100	25	39	13,4	0,70	12 000	8 500	0,81	2211 ETN9	2211 EKTN9
	120	29	50,7	18	0,92	11 000	7 500	1,60	1311 ETN9	1311 EKTN9
	120	43	76,1	24	1,25	11 000	7 500	2,10	2311 ETN9	2311 K
60	110	22	31,2	12,2	0,62	12 000	8 500	0,90	1212 ETN9	1212 EKTN9
	110	28	48,8	17	0,88	11 000	8 000	1,10	2212 ETN9	2212 EKTN9
	130	31	58,5	22	1,12	9 000	6 300	1,95	1312 ETN9	1312 EKTN9
	130	46	87,1	28,5	1,46	9 500	7 000	2,60	2312 ETN9	2312 K
65	120	23	35,1	14	0,72	11 000	7 000	1,15	1213 ETN9	1213 EKTN9
	120	31	57,2	20	1,02	10 000	7 000	1,45	2213 ETN9	2213 EKTN9
	140	33	65	25,5	1,25	8 500	6 000	2,45	1313 ETN9	1313 EKTN9
	140	48	95,6	32,5	1,66	9 000	6 300	3,25	2313 ETN9	2313 K

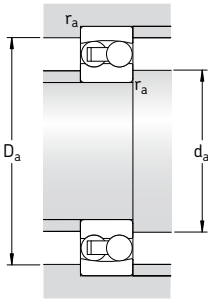

Dimensions				Abutment and fillet dimensions			Calculation factors			
d	d ₂	D ₁	r _{1,2} min	d _a min	D _a max	r _a max	e	Y ₁	Y ₂	Y ₀
mm										
30	40,1	53	1	35,6	56,4	1	0,25	2,5	3,9	2,5
	38,8	55	1	35,6	56,4	1	0,33	1,9	3	2
	44,9	60,9	1,1	37	65	1	0,25	2,5	3,9	2,5
	41,7	60,9	1,1	37	65	1	0,44	1,4	2,2	1,4
35	47	62,3	1,1	42	65	1	0,23	2,7	4,2	2,8
	45,3	64,2	1,1	42	65	1	0,31	2	3,1	2,2
	51,5	69,5	1,5	44	71	1,5	0,25	2,5	3,9	2,5
	46,5	68,4	1,5	44	71	1,5	0,46	1,35	2,1	1,4
40	53,6	68,8	1,1	47	73	1	0,22	2,9	4,5	2,8
	52,4	71,6	1,1	47	73	1	0,28	2,2	3,5	2,5
	61,5	81,5	1,5	49	81	1,5	0,23	2,7	4,2	2,8
	53,7	79,2	1,5	49	81	1,5	0,40	1,6	2,4	1,6
45	57,5	73,7	1,1	52	78	1	0,21	3	4,6	3,2
	55,3	74,6	1,1	52	78	1	0,26	2,4	3,7	2,5
	67,7	89,5	1,5	54	91	1,5	0,23	2,7	4,2	2,8
	60,1	87,4	1,5	54	91	1,5	0,33	1,9	3	2
50	61,7	79,5	1,1	57	83	1	0,21	3	4,6	3,2
	61,5	81,5	1,1	57	83	1	0,23	2,7	4,2	2,8
	70,3	95	2	61	99	2	0,24	2,6	4,1	2,8
	65,8	94,4	2	61	99	2	0,43	1,5	2,3	1,6
55	70,1	88,4	1,5	64	91	1,5	0,19	3,3	5,1	3,6
	67,7	89,5	1,5	64	91	1,5	0,23	2,7	4,2	2,8
	77,7	104	2	66	109	2	0,23	2,7	4,2	2,8
	72	103	2	66	109	2	0,40	1,6	2,4	1,6
60	78	97,6	1,5	69	101	1,5	0,19	3,3	5,1	3,6
	74,5	98,6	1,5	69	101	1,5	0,24	2,6	4,1	2,8
	91,6	118	2,1	72	118	2	0,22	2,9	4,5	2,8
	76,9	112	2,1	72	118	2	0,33	1,9	3	2
65	85,3	106	1,5	74	111	1,5	0,18	3,5	5,4	3,6
	80,7	107	1,5	74	111	1,5	0,24	2,6	4,1	2,8
	99	127	2,1	77	128	2	0,22	2,9	4,5	2,8
	85,5	122	2,1	77	128	2	0,37	1,7	2,6	1,8

Self-aligning ball bearings d 70 – 120 mm

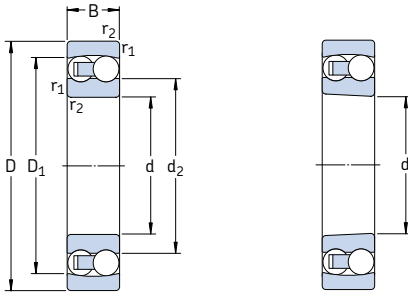

Cylindrical bore

Tapered bore

Principal dimensions			Basic load ratings dynamic static		Fatigue load limit P_u	Speed ratings Reference speed Limiting speed		Mass	Designations Bearing with cylindrical bore tapered bore	
d	D	B	C	C_0				kg	–	
mm			kN		kN	r/min		kg	–	
70	125	24	35,8	14,6	0,75	11 000	7 000	1,25	1214 ETN9	–
	125	31	44,2	17	0,88	10 000	6 700	1,50	2214	–
	150	35	74,1	27,5	1,34	8 500	6 000	3,00	1314	–
	150	51	111	37,5	1,86	8 000	6 000	3,90	2314	–
75	130	25	39	15,6	0,80	10 000	6 700	1,35	1215	1215 K
	130	31	58,5	22	1,12	9 000	6 300	1,60	2215 ETN9	2215 EKTN9
	160	37	79,3	30	1,43	8 000	5 600	3,55	1315	1315 K
	160	55	124	43	2,04	7 500	5 600	4,70	2315	2315 K
80	140	26	39,7	17	0,83	9 500	6 000	1,65	1216	1216 K
	140	33	65	25,5	1,25	8 500	6 000	2,00	2216 ETN9	2216 EKTN9
	170	39	88,4	33,5	1,50	7 500	5 300	4,20	1316	1316 K
	170	58	135	49	2,24	7 000	5 300	6,10	2316	2316 K
85	150	28	48,8	20,8	0,98	9 000	5 600	2,05	1217	1217 K
	150	36	58,5	23,6	1,12	8 000	5 600	2,50	2217	2217 K
	180	41	97,5	38	1,70	7 000	4 800	5,00	1317	1317 K
	180	60	140	51	2,28	6 700	4 800	7,05	2317	2317 K
90	160	30	57,2	23,6	1,08	8 500	5 300	2,50	1218	1218 K
	160	40	70,2	28,5	1,32	7 500	5 300	3,40	2218	2218 K
	190	43	117	44	1,93	6 700	4 500	5,80	1318	1318 K
	190	64	153	57	2,50	6 300	4 500	8,45	2318 M	2318 KM
95	170	32	63,7	27	1,20	8 000	5 000	3,10	1219	1219 K
	170	43	83,2	34,5	1,53	7 000	5 000	4,10	2219 M	2219 KM
	200	45	133	51	2,16	6 300	4 300	6,70	1319	1319 K
	200	67	165	64	2,75	6 000	4 500	9,80	2319 M	–
100	180	34	68,9	30	1,29	7 500	4 800	3,70	1220	1220 K
	180	46	97,5	40,5	1,76	6 700	4 800	5,00	2220 M	2220 KM
	215	47	143	57	2,36	6 000	4 000	8,30	1320	1320 K
	215	73	190	80	3,25	5 600	4 000	12,5	2320 M	2320 KM
110	200	38	88,4	39	1,60	6 700	4 300	5,15	1222	1222 K
	200	53	124	52	2,12	6 000	4 300	7,10	2222 M	2222 KM
	240	50	163	72	2,75	5 300	3 600	12,0	1322 M	1322 KM
120	215	42	119	53	2,12	6 300	4 000	6,75	1224 M	1224 KM

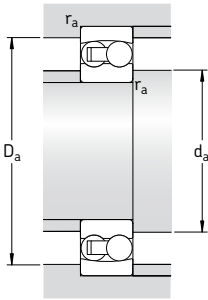

Dimensions				Abutment and fillet dimensions			Calculation factors			
d	d ₂	D ₁	r _{1,2} min	d _a min	D _a max	r _a max	e	Y ₁	Y ₂	Y ₀
mm							-			
70	87,4	109	1,5	79	116	1,5	0,18	3,5	5,4	3,6
	87,5	111	1,5	79	116	1,5	0,27	2,3	3,6	2,5
	97,7	129	2,1	82	138	2	0,22	2,9	4,5	2,8
	91,6	130	2,1	82	138	2	0,37	1,7	2,6	1,8
75	93	116	1,5	84	121	1,5	0,17	3,7	5,7	4
	91,6	118	1,5	84	121	1,5	0,22	2,9	4,5	2,8
	104	138	2,1	87	148	2	0,22	2,9	4,5	2,8
	97,8	139	2,1	87	148	2	0,37	1,7	2,6	1,8
80	101	125	2	91	129	2	0,16	3,9	6,1	4
	99	127	2	91	129	2	0,22	2,9	4,5	2,8
	109	147	2,1	92	158	2	0,22	2,9	4,5	2,8
	104	148	2,1	92	158	2	0,37	1,7	2,6	1,8
85	107	134	2	96	139	2	0,17	3,7	5,7	4
	105	133	2	96	139	2	0,25	2,5	3,9	2,5
	117	155	3	99	166	2,5	0,22	2,9	4,5	2,8
	115	157	3	99	166	2,5	0,37	1,7	2,6	1,8
90	112	142	2	101	149	2	0,17	3,7	5,7	4
	112	142	2	101	149	2	0,27	2,3	3,6	2,5
	122	165	3	104	176	2,5	0,22	2,9	4,5	2,8
	121	164	3	104	176	2,5	0,37	1,7	2,6	1,8
95	120	151	2,1	107	158	2	0,17	3,7	5,7	4
	118	151	2,1	107	158	2	0,27	2,3	3,6	2,5
	127	174	3	109	186	2,5	0,23	2,7	4,2	2,8
	128	172	3	109	186	2,5	0,37	1,7	2,6	1,8
100	127	159	2,1	112	168	2	0,17	3,7	5,7	4
	124	160	2,1	112	168	2	0,27	2,3	3,6	2,5
	136	185	3	114	201	2,5	0,23	2,7	4,2	2,8
	135	186	3	114	201	2,5	0,37	1,7	2,6	1,8
110	140	176	2,1	122	188	2	0,17	3,7	5,7	4
	137	177	2,1	122	188	2	0,28	2,2	3,5	2,5
	154	206	3	124	226	2,5	0,22	2,9	4,5	2,8
120	149	190	2,1	132	203	2	0,19	3,3	5,1	3,6

Self-aligning ball bearings
d 130 – 240 mm

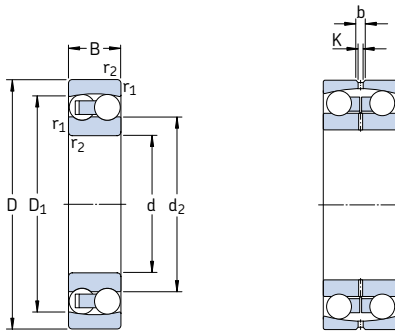

Principal dimensions			Basic load ratings		Fatigue load limit P_u	Speed ratings		Mass	Designation
d	D	B	dynamic C	static C_0		Refer- ence speed	Limiting speed		
mm			kN		kN	r/min		kg	–
130	230	46	127	58,5	2,24	5 600	3 600	8,30	1226 M
150	225	56	57,2	23,6	0,88	5 600	3 400	7,50	13030
180	280	74	95,6	40	1,34	4 500	2 800	16,0	13036
200	280	60	60,5	29	0,97	4 300	2 600	10,7	13940
220	300	60	60,5	30,5	0,97	3 800	2 400	11,0	13944
240	320	60	60,5	32	0,98	3 800	2 200	11,3	13948

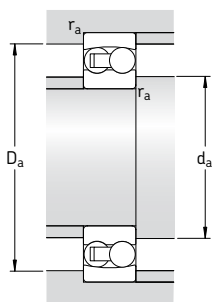

Dimensions						Abutment and fillet dimensions			Calculation factors			
d	\tilde{d}_2	\tilde{D}_1	b	K	$r_{1,2}$ min	d_a min	D_a max	r_a max	e	Y_1	Y_2	Y_0
mm						mm			-			
130	163	204	-	-	3	144	216	2,5	0,19	3,3	5,1	3,6
150	175	203	8,3	4,5	2,1	161	214	2	0,24	2,6	4,1	2,8
180	212	249	13,9	7,5	2,1	191	269	2	0,25	2,5	3,9	2,5
200	229	258	8,3	4,5	2,1	211	269	2	0,19	3,3	5,1	3,6
220	249	278	8,3	4,5	2,1	231	289	2	0,18	3,5	5,4	3,6
240	269	298	8,3	4,5	2,1	251	309	2	0,16	3,9	6,1	4

Sealed self-aligning ball bearings

d 10 – 70 mm

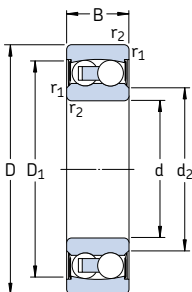

Cylindrical bore

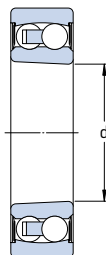

Tapered bore

Principal dimensions			Basic load ratings dynamic static		Fatigue load limit P_u	Limiting speed	Mass	Designations Bearing with cylindrical bore	tapered bore
d	D	B	C	C_0		r/min	kg		
mm			kN		kN			–	
10	30	14	5,53	1,18	0,06	17 000	0,048	2200 E-2RS1TN9	–
12	32	14	6,24	1,43	0,08	16 000	0,053	2201 E-2RS1TN9	–
15	35	14	7,41	1,76	0,09	14 000	0,058	2202 E-2RS1TN9	–
	42	17	10,8	2,6	0,14	12 000	0,11	2302 E-2RS1TN9	–
17	40	16	8,84	2,2	0,12	12 000	0,089	2203 E-2RS1TN9	–
	47	19	12,7	3,4	0,18	11 000	0,16	2303 E-2RS1TN9	–
20	47	18	12,7	3,4	0,18	10 000	0,14	2204 E-2RS1TN9	–
	52	21	14,3	4	0,21	9 000	0,21	2304 E-2RS1TN9	–
25	52	18	14,3	4	0,21	9 000	0,16	2205 E-2RS1TN9	2205 E-2RS1KTN9
	62	24	19	5,4	0,28	7 500	0,34	2305 E-2RS1TN9	–
30	62	20	15,6	4,65	0,24	7 500	0,26	2206 E-2RS1TN9	2206 E-2RS1KTN9
	72	27	22,5	6,8	0,36	6 700	0,51	2306 E-2RS1TN9	–
35	72	23	19	6	0,31	6 300	0,41	2207 E-2RS1TN9	2207 E-2RS1KTN9
	80	31	26,5	8,5	0,43	5 600	0,70	2307 E-2RS1TN9	–
40	80	23	19,9	6,95	0,36	5 600	0,50	2208 E-2RS1TN9	2208 E-2RS1KTN9
	90	33	33,8	11,2	0,57	5 000	0,96	2308 E-2RS1TN9	–
45	85	23	22,9	7,8	0,40	5 300	0,53	2209 E-2RS1TN9	2209 E-2RS1KTN9
	100	36	39	13,4	0,70	4 500	1,30	2309 E-2RS1TN9	–
50	90	23	22,9	8,15	0,42	4 800	0,57	2210 E-2RS1TN9	2210 E-2RS1KTN9
	110	40	43,6	14	0,72	4 000	1,65	2310 E-2RS1TN9	–
55	100	25	27,6	10,6	0,54	4 300	0,79	2211 E-2RS1TN9	2211 E-2RS1KTN9
60	110	28	31,2	12,2	0,62	3 800	1,05	2212 E-2RS1TN9	2212 E-2RS1KTN9
65	120	31	35,1	14	0,72	3 600	1,40	2213 E-2RS1TN9	2213 E-2RS1KTN9
70	125	31	35,8	14,6	0,75	3 400	1,45	2214 E-2RS1TN9	–

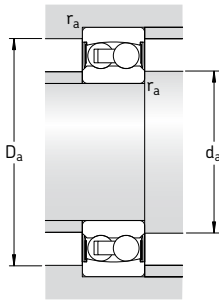

Dimensions				Abutment and fillet dimensions				Calculation factors			
d	d ₂	D ₁	r _{1,2} min	d _a min	d _a max	D _a max	r _a max	e	Y ₁	Y ₂	Y ₀
mm				mm				-			
10	14	24,8	0,6	14	14	25,8	0,6	0,33	1,9	3	2
12	15,5	27,4	0,6	15,5	15,5	27,8	0,6	0,33	1,9	3	2
15	19,1 20,3	30,4 36,3	0,6 1	19 20	19 20	30,8 36,4	0,6 1	0,33 0,31	1,9 2	3 3,1	2 2,2
17	21,1 25,5	35 41,3	0,6 1	21 22	21 25,5	35,8 41,4	0,6 1	0,31 0,30	2 2,1	3,1 3,3	2,2 2,2
20	25,9 28,6	41,3 46,3	1 1,1	25 26,5	25,5 28,5	41,4 45	1 1	0,30 0,28	2,1 2,2	3,3 3,5	2,2 2,5
25	31 32,8	46,3 52,7	1 1,1	30,6 32	31 32,5	46,4 55	1 1	0,28 0,28	2,2 2,2	3,5 3,5	2,5 2,5
30	36,7 40,4	54,1 61,9	1 1,1	35,6 37	36,5 40	56,4 65	1 1	0,25 0,25	2,5 2,5	3,9 3,9	2,5 2,5
35	42,7 43,7	62,7 69,2	1,1 1,5	42 43,5	42,5 43,5	65 71	1 1,5	0,23 0,25	2,7 2,5	4,2 3,9	2,8 2,5
40	49 55,4	69,8 81,8	1,1 1,5	47 49	49 55	73 81	1 1,5	0,22 0,23	2,9 2,7	4,5 4,2	2,8 2,8
45	53,1 60,9	75,3 90	1,1 1,5	52 54	53 60,5	78 91	1 1,5	0,21 0,23	3 2,7	4,6 4,2	3,2 2,8
50	58,1 62,9	79,5 95,2	1,1 2	57 61	58 62,5	83 99	1 2	0,20 0,24	3,2 2,6	4,9 4,1	3,2 2,8
55	65,9	88,5	1,5	64	65,5	91	1,5	0,19	3,3	5,1	3,6
60	73,2	97	1,5	69	73	101	1,5	0,19	3,3	5,1	3,6
65	79,3	106	1,5	74	79	111	1,5	0,18	3,5	5,4	3,6
70	81,4	109	1,5	79	81	116	1,5	0,18	3,5	5,4	3,6

Self-aligning ball bearings with extended inner ring
d 20 – 60 mm

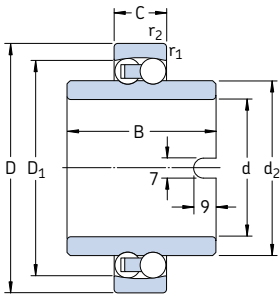

Principal dimensions			Basic load ratings		Fatigue load limit P_u	Limiting speed	Mass	Designation
d	D	C	dynamic C	static C_0				
mm			kN		kN	r/min	kg	–
20	47	14	12,7	3,4	0,18	9 000	0,18	11204 ETN9
25	52	15	14,3	4	0,21	8 000	0,22	11205 ETN9
30	62	16	15,6	4,65	0,24	6 700	0,35	11206 TN9
35	72	17	15,9	5,1	0,27	5 600	0,54	11207 TN9
40	80	18	19	6,55	0,34	5 000	0,72	11208 TN9
45	85	19	21,6	7,35	0,38	4 500	0,77	11209 TN9
50	90	20	22,9	8,15	0,42	4 300	0,85	11210 TN9
60	110	22	30,2	11,6	0,60	3 400	1,15	11212 TN9

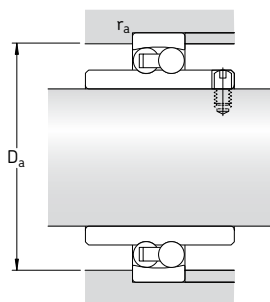

Dimensions					Abutment and fillet dimensions		Calculation factors			
d	d_2	D_1	B	$r_{1,2 \text{ min}}$	$D_a \text{ max}$	$r_a \text{ max}$	e	Y_1	Y_2	Y_0
mm					mm		-			
20	28,9	41	40	1	41,4	1	0,30	2,1	3,3	2,2
25	33,3	45,6	44	1	46,4	1	0,28	2,2	3,5	2,5
30	40,1	53,2	48	1	56,4	1	0,25	2,5	3,9	2,5
35	47,7	60,7	52	1,1	65	1	0,23	2,7	4,2	2,8
40	54	68,8	56	1,1	73	1	0,22	2,9	4,5	2,8
45	57,7	73,7	58	1,1	78	1	0,21	3	4,6	3,2
50	62,7	78,7	58	1,1	83	1	0,21	3	4,6	3,2
60	78	97,5	62	1,5	101	1,5	0,19	3,3	5,1	3,6

Self-aligning ball bearings on adapter sleeve

d_1 17 – 45 mm

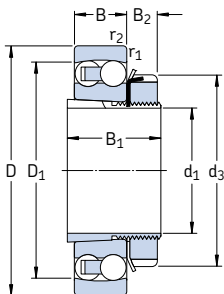

Open bearing

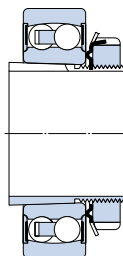

Sealed bearing

Principal dimensions			Basic load ratings dynamic static		Fatigue load limit P_u	Speed ratings Reference speed Limiting speed		Mass Bearing + sleeve	Designations Bearing	Adapter sleeve
d_1	D	B	C	C_0		Reference speed	Limiting speed	kg		
mm			kN		kN	r/min		kg	–	
17	47	14	12,7	3,4	0,18	32 000	20 000	0,16	1204 EKTN9	H 204
20	52	15	14,3	4	0,21	28 000	18 000	0,21	1205 EKTN9	H 205
	52	18	16,8	4,4	0,23	26 000	18 000	0,23	2205 EKTN9	H 305
	52	18	14,3	4	0,21	–	9 000	0,23	2205 E-2RS1KTN9	H 305 C
	62	17	19	5,4	0,28	22 000	15 000	0,33	1305 EKTN9	H 305
25	62	16	15,6	4,65	0,24	24 000	15 000	0,32	▶ 1206 EKTN9	H 206
	62	20	23,8	6,7	0,35	22 000	15 000	0,36	2206 EKTN9	H 306
	62	20	15,6	4,65	0,24	–	7 500	0,36	2206 E-2RS1KTN9	H 306 C
	72	19	22,5	6,8	0,36	19 000	13 000	0,49	1306 EKTN9	H 306
	72	27	31,2	8,8	0,45	18 000	13 000	0,61	2306 K	H 2306
30	72	17	19	6	0,31	20 000	13 000	0,44	▶ 1207 EKTN9	H 207
	72	23	30,7	8,8	0,46	18 000	12 000	0,54	2207 EKTN9	H 307
	72	23	19	6	0,31	–	6 300	0,55	2207 E-2RS1KTN9	H 307 C
	80	21	26,5	8,5	0,43	16 000	11 000	0,65	1307 EKTN9	H 307
	80	31	39,7	11,2	0,59	18 000	12 000	0,84	2307 EKTN9	H 2307
35	80	18	19,9	6,95	0,36	18 000	11 000	0,58	▶ 1208 EKTN9	H 208
	80	23	31,9	10	0,51	16 000	11 000	0,58	2208 EKTN9	H 308
	80	23	19,9	6,95	0,36	–	5 600	0,67	2208 E-2RS1KTN9	H 308 C
	90	23	33,8	11,2	0,57	14 000	9 500	0,85	1308 EKTN9	H 308
	90	33	54	16	0,82	14 000	10 000	1,10	2308 EKTN9	H 2308
40	85	19	22,9	7,8	0,40	17 000	11 000	0,68	▶ 1209 EKTN9	H 209
	85	23	32,5	10,6	0,54	15 000	10 000	0,78	2209 EKTN9	H 309
	85	23	22,9	7,8	0,40	–	5 300	0,76	2209 E-2RS1KTN9	H 309 C
	100	25	39	13,4	0,70	12 000	8 500	1,20	1309 EKTN9	H 309
	100	36	63,7	19,3	1	13 000	9 000	1,40	2309 EKTN9	H 2309
45	90	20	26,5	9,15	0,48	16 000	10 000	0,77	▶ 1210 EKTN9	H 210
	90	23	33,8	11,2	0,57	14 000	9 500	0,87	2210 EKTN9	H 310
	90	23	22,9	8,15	0,42	–	4 800	0,84	2210 E-2RS1KTN9	H 310 C
	110	27	43,6	14	0,72	12 000	8 000	1,45	1310 EKTN9	H 310
	110	40	63,7	20	1,04	14 000	9 500	1,90	2310 K	H 2310

▶ Bearings and sleeves also available as KAM self-aligning ball bearing kits (→ page 474)

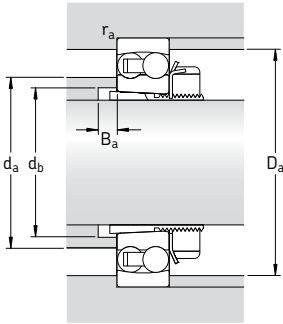

Dimensions						Abutment and fillet dimensions					Calculation factors			
d_1	d_3	D_1	B_1	B_2	$r_{1,2}$	d_a	d_b	D_a	B_a	r_a	e	Y_1	Y_2	Y_0
mm						mm					-			
17	32	41	24	7	1	28,5	23	41,4	5	1	0,30	2,1	3,3	2,2
20	38	45,6	26	8	1	33	28	46,4	5	1	0,28	2,2	3,5	2,5
	38	46,1	29	8	1	32	28	46,4	5	1	0,35	1,8	2,8	1,8
	38	46,3	29	9	1	31	28	46,4	5	1	0,28	2,2	3,5	2,5
	38	52,5	29	8	1,1	37	28	55	6	1	0,28	2,2	3,5	2,5
25	45	53	27	8	1	40	33	56,4	5	1	0,25	2,5	3,9	2,5
	45	55	31	8	1	38	33	56,4	5	1	0,33	1,9	3	2
	45	54,1	31	9	1	36	33	56,4	5	1	0,25	2,5	3,9	2,5
	45	60,9	27	8	1,1	44	33	65	6	1	0,25	2,5	3,9	2,5
	45	60,9	38	8	1,1	41	35	65	5	1	0,44	1,4	2,2	1,4
30	52	62,3	29	9	1,1	47	38	65	-	1	0,23	2,7	4,2	2,8
	52	64,2	35	9	1,1	45	39	65	5	1	0,31	2	3,1	2,2
	52	62,7	35	10	1,1	42	39	65	5	1	0,23	2,7	4,2	2,8
	52	69,5	35	9	1,5	51	39	71	7	1,5	0,25	2,5	3,9	2,5
	52	68,4	43	9	1,5	46	40	71	5	1,5	0,46	1,35	2,1	1,4
35	58	68,8	31	10	1,1	53	43	73	6	1	0,22	2,9	4,5	2,8
	58	71,6	36	10	1,1	52	44	73	6	1	0,28	2,2	3,5	2,5
	58	69,8	36	11	1,1	49	44	73	6	1	0,22	2,9	4,5	2,8
	58	81,5	36	10	1,5	61	44	81	6	1,5	0,23	2,7	4,2	2,8
	58	79,2	46	10	1,5	53	45	81	6	1,5	0,40	1,6	2,4	1,6
40	65	73,7	33	11	1,1	57	48	78	6	1	0,21	3	4,6	3,2
	65	74,6	39	11	1,1	55	50	78	8	1	0,26	2,4	3,7	2,5
	65	75,3	39	12	1,1	53	50	78	8	1	0,21	3	4,6	3,2
	65	89,5	39	11	1,5	67	50	91	6	1,5	0,23	2,7	4,2	2,8
	65	87,4	50	11	1,5	60	50	91	6	1,5	0,33	1,9	3	2
45	70	79,5	35	12	1,1	62	53	83	6	1	0,21	3	4,6	3,2
	70	81,5	42	12	1,1	61	55	83	10	1	0,23	2,7	4,2	2,8
	70	79,5	42	13	1,1	58	55	83	10	1	0,20	3,2	4,9	3,2
	70	95	42	12	2	70	55	99	6	2	0,24	2,6	4,1	2,8
	70	94,4	55	12	2	65	56	99	6	2	0,43	1,5	2,3	1,6

Self-aligning ball bearings on adapter sleeve

d_1 50 – 80 mm

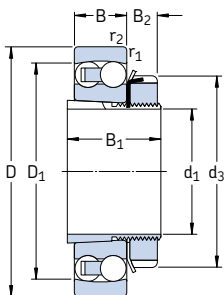

Open bearing

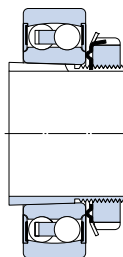

Sealed bearing

Principal dimensions			Basic load ratings dynamic static		Fatigue load limit P_u	Speed ratings Refer- ence speed Limiting speed		Mass Bearing + sleeve	Designations Bearing	Adapter sleeve
d_1	D	B	C	C_0				kg	–	
mm			kN		kN	r/min		kg	–	
50	100	21	27,6	10,6	0,54	14 000	9 000	0,99	► 1211 EKTN9	H 211
	100	25	39	13,4	0,70	12 000	8 500	1,15	2211 EKTN9	H 311
	100	25	27,6	10,6	0,54	–	4 300	1,10	2211 E-2RS1KTN9	H 311 C
	120	29	50,7	18	0,92	11 000	7 500	1,90	1311 EKTN9	H 311
	120	43	76,1	24	1,25	11 000	7 500	2,40	2311 K	H 2311
55	110	22	31,2	12,2	0,62	12 000	8 500	1,20	1212 EKTN9	H 212
	110	28	48,8	17	0,88	11 000	8 000	1,45	2212 EKTN9	H 312
	110	28	31,2	12,2	0,62	–	3 800	1,40	2212 E-2RS1KTN9	H 312 C
	130	31	58,5	22	1,12	9 000	6 300	2,15	1312 EKTN9	H 312
	130	46	87,1	28,5	1,46	9 500	7 000	2,95	2312 K	H 2312
60	120	23	35,1	14	0,72	11 000	7 000	1,45	1213 EKTN9	H 213
	120	31	57,2	20	1,02	10 000	7 000	1,80	2213 EKTN9	H 313
	120	31	35,1	14	0,72	–	3 600	1,75	2213 E-2RS1KTN9	H 313 C
	140	33	65	25,5	1,25	8 500	6 000	2,85	1313 EKTN9	H 313
	140	48	95,6	32,5	1,66	9 000	6 300	3,60	2313 K	H 2313
65	130	25	39	15,6	0,80	10 000	6 700	2,00	1215 K	H 215
	130	31	58,5	22	1,12	9 000	6 300	2,30	2215 EKTN9	H 315
	160	37	79,3	30	1,43	8 000	5 600	4,20	1315 K	H 315
	160	55	124	43	2,04	7 500	5 600	5,55	2315 K	H 2315
70	140	26	39,7	17	0,83	9 500	6 000	2,40	1216 K	H 216
	140	33	65	25,5	1,25	8 500	6 000	2,85	2216 EKTN9	H 316
	170	39	88,4	33,5	1,50	7 500	5 300	5,00	1316 K	H 316
	170	58	135	49	2,24	7 000	5 300	7,10	2316 K	H 2316
75	150	28	48,8	20,8	0,98	9 000	5 600	2,95	1217 K	H 217
	150	36	58,5	23,6	1,12	8 000	5 600	3,30	2217 K	H 317
	180	41	97,5	38	1,70	7 000	4 800	6,00	1317 K	H 317
	180	60	140	51	2,28	6 700	4 800	8,15	2317 K	H 2317
80	160	30	57,2	23,6	1,08	8 500	5 300	3,50	1218 K	H 218
	160	40	70,2	28,5	1,32	7 500	5 300	5,50	2218 K	H 318
	190	43	117	44	1,93	6 700	4 500	6,90	1318 K	H 318
	190	64	153	57	2,50	6 300	4 500	9,80	2318 KM	H 2318

► Bearings and sleeves also available as KAM self-aligning ball bearing kits (→ page 474)

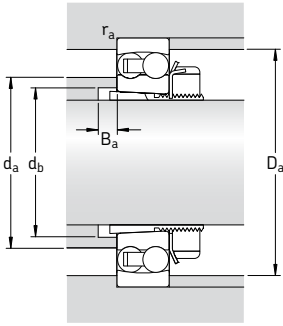

Dimensions						Abutment and fillet dimensions					Calculation factors			
d ₁	d ₃	D ₁	B ₁	B ₂	r _{1,2}	d _a	d _b	D _a	B _a	r _a	e	Y ₁	Y ₂	Y ₀
mm						mm					-			
50	75	88,4	37	12,5	1,5	70	60	91	7	1,5	0,19	3,3	5,1	3,6
	75	89,5	45	12,5	1,5	67	60	91	11	1,5	0,23	2,7	4,2	2,8
	75	88,5	45	13	1,5	65	60	91	11	1,5	0,19	3,3	5,1	3,6
	75	104	45	12,5	2	77	60	109	7	2	0,23	2,7	4,2	2,8
	75	103	59	12,5	2	72	61	109	7	2	0,40	1,6	2,4	1,6
55	80	97,6	38	12,5	1,5	78	64	101	7	1,5	0,19	3,3	5,1	3,6
	80	98,6	47	12,5	1,5	74	65	101	9	1,5	0,24	2,6	4,1	2,8
	80	97	47	13,5	1,5	73	65	101	9	1,5	0,19	3,3	5,1	3,6
	80	118	47	12,5	2,1	87	65	118	7	2	0,22	2,9	4,5	2,8
	80	112	62	12,5	2,1	76	66	118	7	2	0,33	1,9	3	2
60	85	106	40	13,5	1,5	85	70	111	7	1,5	0,18	3,5	5,4	3,6
	85	107	50	13,5	1,5	80	70	111	9	1,5	0,24	2,6	4,1	2,8
	85	106	50	14,5	1,5	79	70	111	7	1,5	0,18	3,5	5,4	3,6
	85	127	50	13,5	2,1	89	70	128	7	2	0,22	2,9	4,5	2,8
	85	122	65	13,5	2,1	85	72	128	7	2	0,37	1,7	2,6	1,8
65	98	116	43	14,5	1,5	93	80	121	7	1,5	0,17	3,7	5,7	4
	98	118	55	14,5	1,5	93	80	121	13	1,5	0,22	2,9	4,5	2,8
	98	138	55	14,5	2,1	104	80	148	7	2	0,22	2,9	4,5	2,8
	98	139	73	14,5	2,1	97	82	148	7	2	0,37	1,7	2,6	1,8
70	105	125	46	17	2	101	85	129	7	2	0,16	3,9	6,1	4
	105	127	59	17	2	99	85	129	13	2	0,22	2,9	4,5	2,8
	105	147	59	17	2,1	109	85	158	7	2	0,22	2,9	4,5	2,8
	105	148	78	17	2,1	104	88	158	7	2	0,37	1,7	2,6	1,8
75	110	134	50	18	2	107	90	139	8	2	0,17	3,7	5,7	4
	110	133	63	18	2	105	91	139	13	2	0,25	2,5	3,9	2,5
	110	155	63	18	3	117	91	166	8	2,5	0,22	2,9	4,5	2,8
	110	157	82	18	3	111	94	166	8	2,5	0,37	1,7	2,6	1,8
80	120	142	52	18	2	112	95	149	8	2	0,17	3,7	5,7	4
	120	142	65	18	2	112	96	149	11	2	0,27	2,3	3,6	2,5
	120	165	65	18	3	122	96	176	8	2,5	0,22	2,9	4,5	2,8
	120	164	86	18	3	115	100	176	8	2,5	0,37	1,7	2,6	1,8

Self-aligning ball bearings on adapter sleeve
d₁ 85 – 110 mm

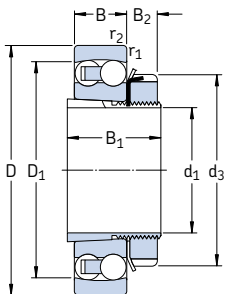

Principal dimensions			Basic load ratings		Fatigue load limit P _u	Speed ratings		Mass Bearing + sleeve	Designations Bearing	Adapter sleeve
d ₁	D	B	dynamic	static		Refer-ence speed	Limiting speed			
mm			kN		kN	r/min		kg	–	
85	170	32	63,7	27	1,20	8 000	5 000	4,25	1219 K	H 219
	170	43	83,2	34,5	1,53	7 000	5 000	5,30	2219 KM	H 319
	200	45	133	51	2,16	6 300	4 300	7,90	1319 K	H 319
90	180	34	68,9	30	1,29	7 500	4 800	5,00	1220 K	H 220
	180	46	97,5	40,5	1,76	6 700	4 800	6,40	2220 KM	H 320
	215	47	143	57	2,36	6 000	4 000	9,65	1320 K	H 320
	215	73	190	80	3,25	5 600	4 000	14,0	2320 KM	H 2320
100	200	38	88,4	39	1,60	6 700	4 300	6,80	1222 K	H 222
	200	53	124	52	2,12	6 000	4 300	8,85	2222 KM	H 322
	240	50	163	72	2,75	5 300	3 600	13,5	1322 KM	H 322
110	215	42	119	53	2,12	6 300	4 000	8,30	1224 KM	H 3024

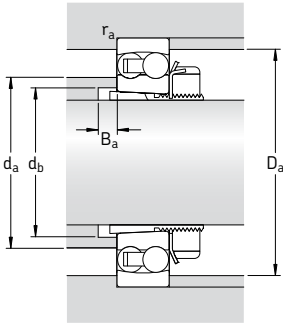

Dimensions							Abutment and fillet dimensions					Calculation factors			
d_1	d_3	D_1	B_1	B_2	$r_{1,2 \min}$	$d_{a \max}$	$d_{b \min}$	$D_{a \max}$	$B_{a \min}$	$r_{a \max}$	e	Y_1	Y_2	Y_0	
mm							mm					-			
85	125	151	55	19	2,1	120	100	158	8	2	0,17	3,7	5,7	4	
	125	151	68	19	2,1	118	102	158	10	2	0,27	2,3	3,6	2,5	
	125	174	68	19	3	127	102	186	8	2,5	0,23	2,7	4,2	2,8	
90	130	159	58	20	2,1	127	106	168	8	2	0,17	3,7	5,7	4	
	130	160	71	20	2,1	124	108	168	9	2	0,27	2,3	3,6	2,5	
	130	185	71	20	3	136	108	201	8	2,5	0,23	2,7	4,2	2,8	
	130	186	97	20	3	130	110	201	8	2,5	0,37	1,7	2,6	1,8	
100	145	176	63	21	2,1	140	116	188	8	2	0,17	3,7	5,7	4	
	145	177	77	21	2,1	137	118	188	8	2	0,28	2,2	3,5	2,5	
	145	206	77	21	3	154	118	226	10	2,5	0,22	2,9	4,5	2,8	
110	145	190	72	22	2,1	150	127	203	12	2	0,19	3,3	5,1	3,6	